



Operating Instructions

863 Valley View Road, Eighty Four, PA 15330
724-941-9701 • skcinc.com

Polypropylene Fitted Breath-gas Analysis Bags Cat. Nos. 249-01-PP and 269-01-PP



SKC Polypropylene Fitted Breath-gas Analysis Bags are ideal for collecting and storing human breath samples. The samples are subsequently analyzed for volatile organic compounds (VOCs) or volatile sulfur compounds (VSCs). These bags are constructed of FlexFoil® PLUS or Tedlar® material. The fitting adapter and plastic mouthpiece allow easy sample collection and facilitate sample removal by gas-tight syringe for gas chromatography (GC) analysis.

Guidelines for Bag Sampling



Wear gloves when handling the bag and fittings (*photos are shown without gloves for clarity*).

1. Long-term storage of samples in bags is not recommended.
2. SKC sample bags are designed for sampling air at atmospheric pressure only. Attempting to pressurize the bag can result in bag rupture and sample loss. Do not ship bag samples by air freight in a non-pressurized cargo cabin. Bags can burst under such conditions.
3. All federal and state packaging and transporting regulations apply.
4. Failure to follow warnings and cautions voids any warranty.
5. **Do not reuse sample bags.**
6. Due to the physical properties of the FlexFoil bag material, minor crimps and creases may appear on bags during manufacturing, quality testing, and user handling. These marks only affect the aesthetics of the bag and not its performance. FlexFoil bags exhibiting minor crimps and creases are not subject to replacement or refund as functionality is not affected.
7. Do not use sample bags to sample compounds with boiling points > 249.9 F (121 C).
8. SKC bag fitting valves are extremely durable but are not intended for use as handles or hanging devices. This type of handling may damage the seal, causing leakage. This is considered to be misuse and will void the SKC warranty.

Preparing the Fitting

1. Remove a clean fitting adapter from packaging.
2. Remove a clean, **single-use** plastic mouthpiece from packaging and insert the smaller end into the larger opening of the fitting adapter.
3. Gently push other narrower end of the fitting adapter over the side stem of the polypropylene fitting on the bag.



Sampling

1. Open the fitting by placing the bag on a flat surface and, while holding the side stem, turning the entire upper portion of the fitting (including the septum cap and septum body to which it is attached) counterclockwise one revolution. The fitting is now open.

 **Do not turn side stem.**

2. Provide breathing instructions to the test subject. Have subject place lips on the plastic mouthpiece and blow accordingly to collect the desired sample volume.

 **Do not over-inflate the sample bag (see below).**

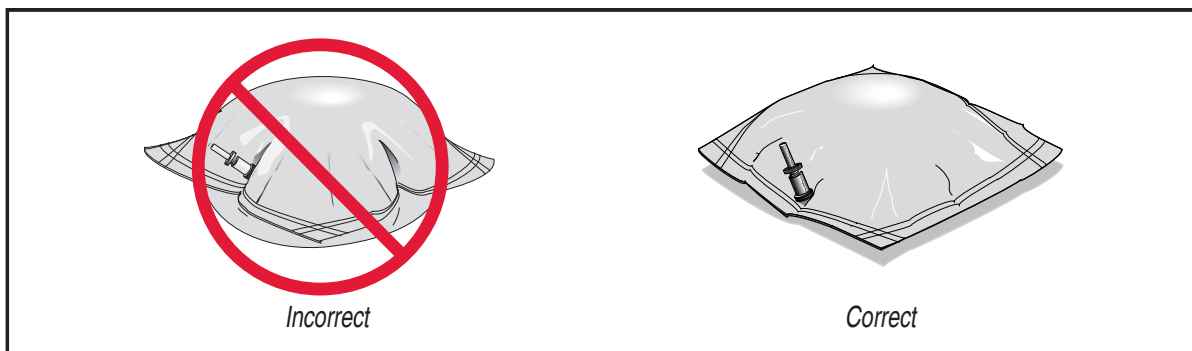

3. **Immediately** remove the mouthpiece from the lips of the test subject and close the breath-gas fitting by holding the side stem and turning the entire upper portion of the fitting (including the septum cap and septum body to which it is attached) clockwise until snug. The fitting is now closed.





4. Holding the fitting with one hand, pull the fitting adapter and attached mouthpiece off of the side stem with the other hand.
5. The fitting adapter and single-use mouthpiece may be disposed of in regular trash.



Shipping

If sending the bags containing breath-gas samples to a laboratory for analysis, place the bags in their original packaging and ship.

Removing the Sample from the Bag

-  The outside diameter of the syringe needle should not be larger than 22 gauge (0.028 inch).
-  Do not allow the syringe needle to puncture the bag material when piercing the septum.

1. Using a gas-tight syringe and needle, carefully insert the needle into the syringe port in the center of the white or brown septum cap and pierce the septum.
2. Use the syringe to withdraw the sample.
3. Analyze the sample.

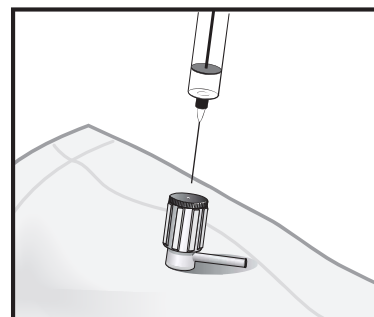

Reference

Mochalski, P., Wzorek, B., Sliwka, I., and Amann, A., Suitability of Different Polymer Bags for Storage of Volatile Sulfur Compounds Relevant to Breath Analysis, *Journal of Chromatography B*, Vol. 877, Issue 3, Jan. 15, 2009, pp. 189-196, <http://dx.doi.org/10.1016/j.jchromb.2008.12.003>

For sample bag stability data, see www.skinc.com/media/documents/1805.pdf.

SKC Limited Warranty and Return Policy

SKC products are subject to the SKC Limited Warranty and Return Policy, which provides SKC's sole liability and the buyer's exclusive remedy. To view the complete SKC Limited Warranty and Return Policy, go to skcinc.com/warranty.

skcinc.com