



[www.skcltd.com](http://www.skcltd.com)

## Universal Air Sampling Pump

### Operating Instructions



This manual covers the following models:  
**224-44MTX, 224-PCMTX4, 224-PCMTX8**

## Purchase Details and Service History

Thank you for choosing an SKC product. Your purchase is covered by our warranty, details of which can be found inside the rear cover of this manual.

Product Model Number	Product Serial Number	Date of Purchase

SKC recommends a minimum service interval of one year for this product. The first service is due one year from the date of purchase, and then at yearly intervals on this date. However, it is the responsibility of the user to perform a risk assessment to determine the necessary frequency of servicing that is required.

Service	Date	Service	Date	Service	Date
1		5		9	
2		6		10	
3		7		11	
4		8		12	

Please note that SKC Ltd are the only authorised service centre in the UK, guaranteeing you access to the full range of genuine SKC replacement parts. For all other areas a full list of SKC approved distributors and service centres can be found at [www.skcltd.com](http://www.skcltd.com)

SKC UK service centre - Phone: +44 (0)1258 480188 Email: [info@skcltd.com](mailto:info@skcltd.com)

Intrinsic Safety Information..... 2

Specifications..... 4

General Information ..... 8

Diagram of the Universal MTX Pump ..... 10

Pump Controls Layout ..... 12

Getting Started..... 13

Operating the Timer (224-PCMTX8 Only) ..... 16

Low Flow Sampling..... 20

Troubleshooting ..... 22

Care of the Battery Pack..... 24

Universal MTX Pump Components..... 26

Universal MTX Pump Replacement Parts ..... 27

Universal MTX Pump Accessories ..... 28

Warranty Information..... 32



## The Universal MTX pump range

- Complies with the EU ATEX Directive 2014/34/EU on equipment intended for use in potentially explosive atmospheres within the European Union. The Universal MTX pump range carries the following markings:



II 1G Ex ia IIC T4 Ga

- ATEX certificate number: SIRA 02ATEX2157.  
Standards applied: EN IEC 60079-0:2018 and EN 60079-11:2012.
- **Note:** A copy of the ATEX certificate can be downloaded from the SKC Ltd website at: <https://www.skcltd.com/documentation/certificates/product-approval-certificates.html>
- The equipment may be used in zones 0, 1 & 2 with flammable gases and vapours with apparatus groups IIA, IIB & IIC and with temperature classes T1, T2, T3 & T4.
- The equipment is only certified for use in ambient temperatures in the range -20 to +40°C and should not be used outside this range.
- The battery pack should not be charged in a hazardous area.
- Use only SKC approved chargers designated for the model.
- The equipment has not been assessed as a safety related device (as referred to in Directive 2014/34/EU Annex II, clause 1.5).

- The equipment should not be used if damaged in a way that could invalidate intrinsic safety. Such defects might include cracking of the battery pack enclosure and internal encapsulant such that internal components or cells are exposed. It is the responsibility of the user to ensure that the pump is in an acceptable condition for use in hazardous locations.

## **Important note about intrinsic safety**

If you are unsure as to whether the Universal pump you have purchased is suitable for your environment, check with your site manager or responsible person BEFORE USE that the intrinsic safety rating on the product meets your site requirements. SKC personnel are unable to recommend the appropriate safety rating for your site.

## All models

- Weight: 915 g
- Casing IP rating: IP20
- Flow range:  
1000 - 4000 ml/min (constant flow operation)  
5 - 500 ml/min with adapter (constant pressure operation)
- Flow control:  $\pm 5\%$  set point constant flow
- Flow indicator: Scale range 0.5 - 5.5 l/min
- Battery pack: NiMH rechargeable, 2.0 Ah, 4.8 V
- Storage & operating temperature:  $-20^{\circ}\text{C}$  to  $+40^{\circ}\text{C}$
- Operating humidity: 0 to 95% RH
- Compensation range:

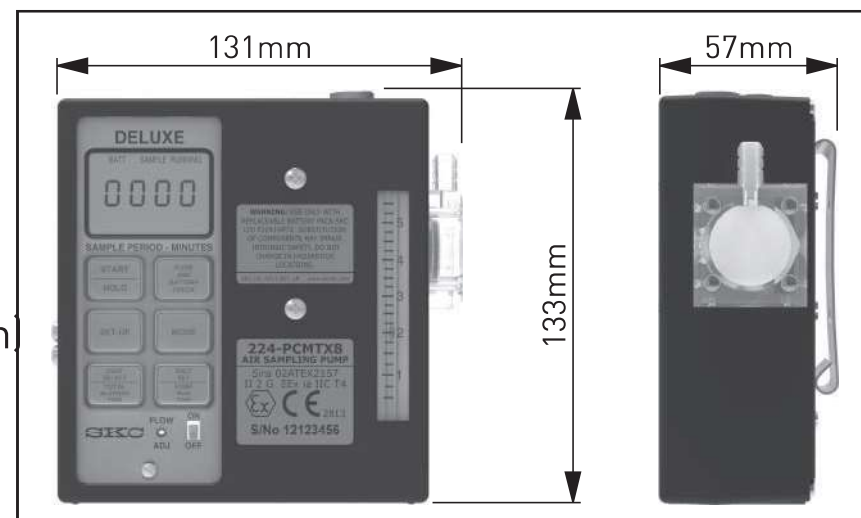

Flow rate (l/min)	Back Pressure (inches of water)	Typical sample media back pressure: IOM sampler with GFA filter at 4 l/min = approximately 10 inches of water IOM sampler with 0.8 $\mu\text{m}$ MCE filter at 2 l/min = approximately 15 inches of water
1	5 - 30	
2	0 - 25	
3	0 - 20	
4	0 - 10	

- Typical run time: 8 hours minimum at 3000 ml/min and 20 inches of water back pressure

**224-PCMTX4 & 224-PCMTX8 only:**

- Timer: Run time display 0 to 9999 minutes  
Hold feature to pause pump and timer  
Fault shutdown for low battery and high back pressure with timer freeze

**224-PCMTX8 only:**

- Timer: Delayed start up to 9999 minutes  
Timed shut down

**Note:**

SKC Limited reserve the right to make changes to the specification and design of this product at any time without prior notice to the end user.

<b>Pump Features</b>	
All Models	
Battery charging options	SKC offer two battery charger options for the Universal MTX series pumps, a single charger (Part No. 223-203A) and a five station charger (Part No. 223-103A). Both charger models provide optimum charging of the NiMH battery packs used in the Universal MTX series pumps, based on a timed (16 hour) constant current charging phase followed by a switch to a trickle charging rate to prevent overcharging.
Mains power option	The Universal MTX series pumps can also be powered from the electrical mains supply using a 'battery eliminator' (Part Nos. 223-305B - Euro 2 pin plug, 223-305C UK 3 pin plug). This accessory comprises a mains adaptor and dummy battery pack which is fitted to the pump in place of the standard battery pack. Please note that the pump's ATEX certification is invalidated when using the battery eliminator, and therefore must not be used in hazardous areas when the battery eliminator is fitted.
Anti-tamper cover	The pump controls are situated beneath a clear anti-tamper cover, requiring a tool for removal. This helps prevent tampering during a sample run.
Low battery shutdown	Automatic pump shutdown in the event of a low battery condition. Prevents degradation of battery pack due to over-discharge.
Flow indicator	Built in rotameter to indicate airflow during sampling. Gives visual indication of changes in flow rate during a sample due to filter loading or constricted tubing for example. Note the flow indicator must not be used to calibrate the sample flow rate.
Particulate trap	Built in replaceable filter to trap particles that would otherwise contaminate the pump mechanism.



<b>Pump Features</b>	
224-PCMTX4 & 224-PCMTX8 Only	
LCD screen	LCD screen indicates elapsed sample run time in minutes up to 9999 minutes (approximately one week). Also displays operating mode, battery condition and flow fault condition. Elapsed sample time is retained on screen in the event of low battery or flow fault shutdown.
Sample hold function	Enables pausing and restarting of the pump during a sample.
Flow fault function	Indicates flow fault due to obstructed tubing or excessive filter loading. Shuts the pump down if the condition persists for longer than 15 seconds. Automatically attempts four restarts before shutting down completely.
224-PCMTX8 Only	
Programmable run time	Sample run time programmable in minutes, via keypad and LCD screen. Pump automatically shuts down at end of sample and elapsed run time is retained on LCD screen.
Programmable delayed start time	Sample start delay time programmable in minutes, via keypad and LCD screen. Start delay countdown display on LCD screen in operation.
Intermittent sampling function	Automatically calculates and controls on/off timing for multiple sample periods.

## 1) Pump Models

224-44MTX	Standard pump with simple on/off control.
224-PCMTX4	Intermediate pump with on/off control, sample hold and elapsed run time display.
224-PCMTX8	Deluxe pump with full timer control and timer display.

## 2) Care of Universal MTX Series Pumps

- Always use the correct SKC batteries and battery chargers designated for the Universal MTX series pumps.
- Never run the pump long term without a tube or filter medium in place.
- When carrying out sampling using long term colour change tubes always use a tandem tube holder with trap tube. This will prevent the aggressive fumes generated by these tubes from entering and damaging the pump mechanism.
- When carrying out sampling using impingers always fit a trap between the impinger and pump inlet. This will prevent the possibility of the fluid used in the impinger from entering and damaging the pump mechanism. As a further precaution always ensure that the pump flow rate is set to below 1 litre/min before connecting the trap and impinger to the pump inlet. For stability use the accessory mounting screws (refer to pump diagram on pages 10 and 11) to fix the impinger bracket to the front of the pump.
- The Universal MTX series pump cases are IP20 rated, they are not rated as water or splashproof and therefore must not be used where it is possible for water to enter the pump casing.
- Universal MTX series pumps are fitted with a particulate filter which is easy to replace. For general maintenance replace the filter every 2-3 months or if it appears dirty. New filters are white in colour (order Part No. P2240901).

**Warning - Failure to follow these guidelines will void the product warranty.**

### 3) Non ATEX Certified Variants of the Universal Pump

The Universal pumps are also produced in a variant range which is UL certified for intrinsic safety and these pumps are therefore not suitable for use in potentially explosive atmospheres in Europe where ATEX approval is mandatory.

Pump components vary between the UL and ATEX certified variants, therefore components must not be interchanged between these pumps. If in any doubt please contact SKC Ltd customer services for advice.

### 4) Sampling Methods

This instruction manual provides the necessary information to set up and operate the Universal MTX series pumps. For more detailed information on specific sampling methods please refer to SKC's Step-By-Step Guide to Air Sampling (Part No. 224-G1). To obtain a free copy please contact SKC Ltd customer services on +44 (0) 1258 480188 or download at [www.skcltd.com](http://www.skcltd.com).

### 5) Waste Electrical and Electronic Equipment



This product is marked with the crossed out wheelevator bin symbol, which identifies that it falls within the scope of the EU Directive 2002/96/EC and the 2013 UK Regulations on waste electrical and electronic equipment (WEEE). At the end of its useful life, this product must be disposed of in an environmentally sound way as detailed in the Directive / Regulations. Note that the battery pack must be separated from the pump and disposed of as detailed in the Batteries Directive (see below). Please contact your local distributor or SKC Ltd for further details on how to comply with the requirements of the WEEE Directive. SKC Ltd's producer registration number is WEE/KH0054TQ.

### 6) Waste Batteries

The NiMH battery pack supplied with this pump and any spare battery packs purchased for it, fall within the scope of the EU Directive 2006/66/EC and the 2009 UK Regulations on batteries and accumulators and waste batteries and accumulators. At the end of the battery pack's life it must be disposed of in an environmentally sound way as detailed in the Directive / Regulations. Please contact your local distributor or SKC Ltd for further details on how to comply with the requirements of the Batteries Directive. SKC Ltd's batteries producer registration number is BPRN00454.

# Diagram of the Universal MTX Pump

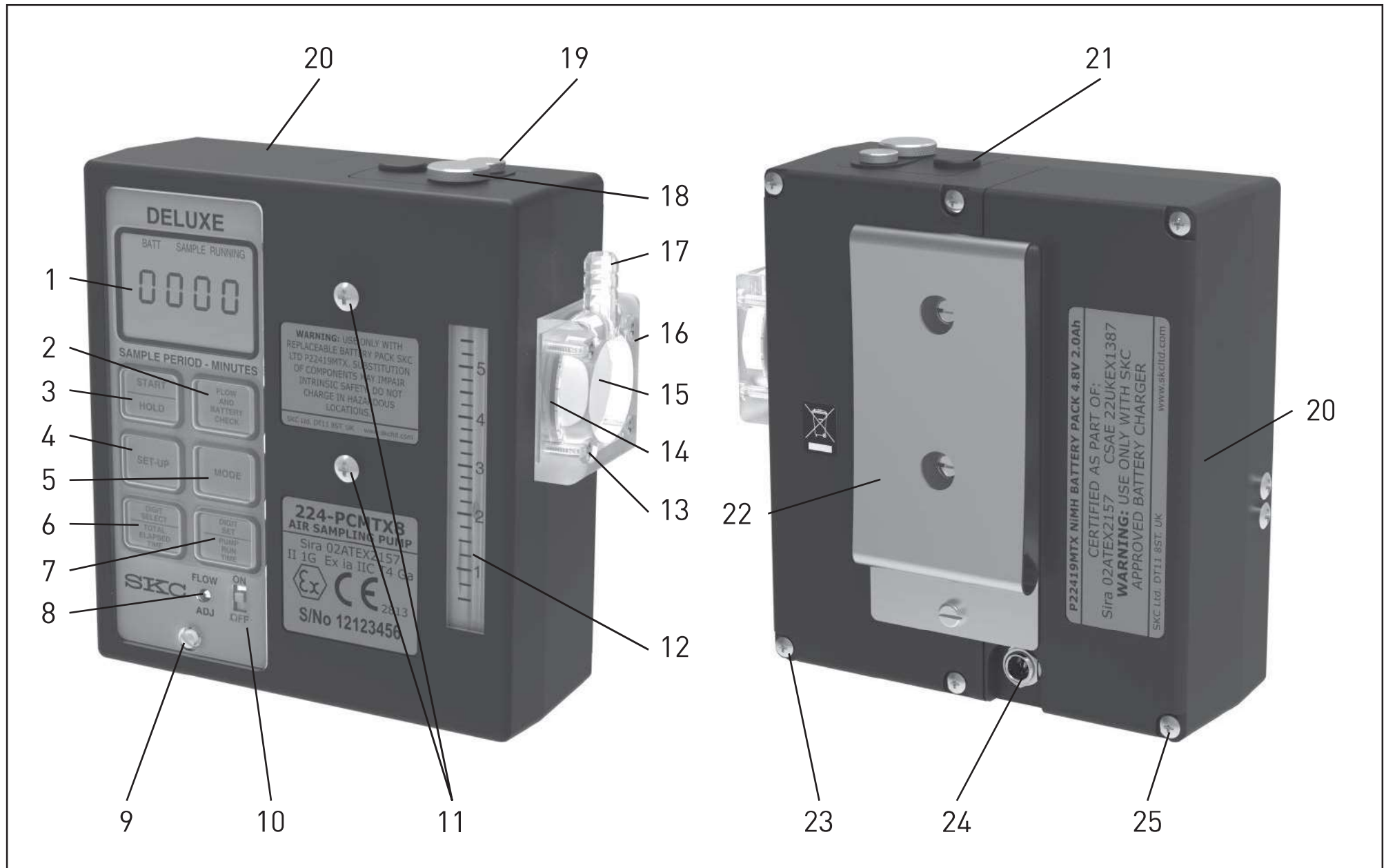

1. LCD screen
2. Flow and battery check key
3. START / HOLD key
4. SET-UP key
5. MODE key
6. SELECT key
7. SET key
8. Flow adjust control screw
9. Anti-tamper cover retaining screw
10. On/off switch
11. Accessory mounting screws
12. Flow indicator
13. Filter housing screws (4qty)
14. Filter O ring seal
15. Inlet protection filter
16. Inlet protection filter housing
17. Air inlet
18. Exhaust port cover
19. Low flow mode screw cover
20. Battery pack
21. Low flow mode regulator cover
22. Belt clip
23. Main case screws (4qty)
24. Battery pack charging jack socket
25. Battery pack screws (2qty)

Standard Control  
Panel : 224-44MTX



Intermediate Control  
Panel : 224-PCMTX4

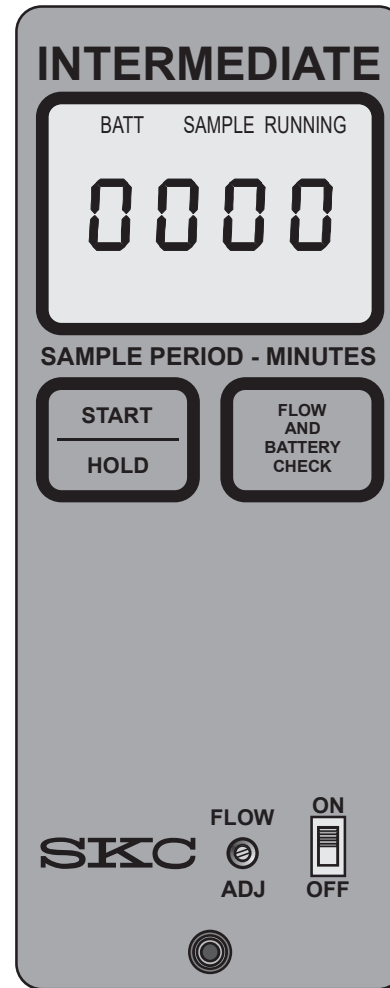

Deluxe Control  
Panel : 224-PCMTX8

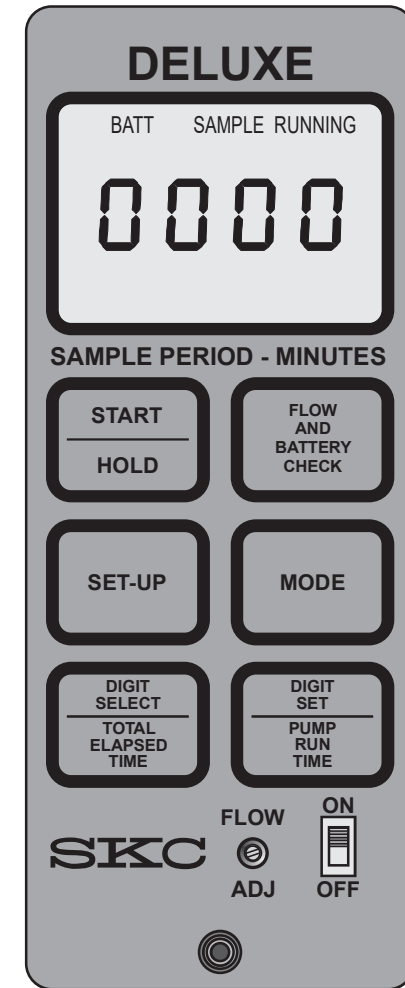

## **APPLICABLE TO ALL MODELS**

### **1) Charging the Battery Pack**

Prior to first use the battery pack should be fully charged, ideally overnight.

The Universal MTX series pumps must only be charged using the correct SKC chargers (Part Nos. 223-203A - single charger, 223-103A - five station charger).

The charger is supplied with mains input plugs suitable for use in the UK, Europe, USA and Australia / New Zealand. Select the correct mains input plug and fit it to the charger.

Plug the charger output jack plug into the mating socket at the rear of the battery pack. Plug the charger into the electrical mains supply and switch on the power. The LED indicator on the charger will illuminate to indicate that the charger is charging at full rate.

After 16 hours the charger will automatically switch to trickle charge, identified by the LED indicator on the charger flashing on and off.

When fully charged disconnect the charger jack plug from the battery pack.

### **2) Accessing the Controls**

To access the controls unfasten the screw retaining the anti-tamper control cover (No. 9) using the large bladed screwdriver attachment of the supplied toolkit, and remove the cover to access the controls.

### **3) On/Off Switch (No. 10)**

Set the on/off switch to the ON position and the pump will start to run. On Models 224-PCMTX4 & 224-PCMTX8, the LCD screen will activate, and show the legends BATT, SAMPLE RUNNING and four zeros. If left running the timer display will increment in one minute steps up to a maximum of 9999 minutes (approximately one week), at which point the timer display will revert to 0000 minutes and continue to increment.

## **4) Flow Adjust Screw (No. 8)**

Use the small bladed screwdriver attachment of the supplied toolkit to turn the flow adjust screw. To increase the flow rate turn clockwise. The span of the flow adjust screw is 12 turns. DO NOT FORCE the flow adjust screw, and ensure the screwdriver end is securely located in the adjust screw slot.

Use a suitable calibrated flowmeter (such as a chek-mate or rotameter) to set the required flow rate, do not use the built in flow indicator.

## **APPLICABLE TO MODELS 224-PCMTX4 & 224-PCMTX8 ONLY**

## **5) START/HOLD Key (No. 3)**

Once the pump has been switched on using the on/off switch, press the START/HOLD key to put the pump into hold mode. The pump will stop running and the timer display will freeze. The legend HOLD is indicated in the bottom left of the LCD screen. Press the START/HOLD key again to restart the pump and the timer will continue to increase from the point at which it was frozen. The words SAMPLE RUNNING will appear in the top right of the LCD screen. Subsequent pressing of this key will toggle between sample running and hold modes.

## **6) FLOW AND BATTERY CHECK Key (No. 2)**

With the pump in hold mode, press the FLOW AND BATTERY CHECK key. The pump will start to run but the timer will remain frozen at its current reading. The legend HOLD in the bottom left of the LCD screen will flash on and off to indicate that the pump is in the flow and battery check mode. Flow checks can now be carried out without the time taken being included on the timer display.

If the pump battery is fully charged the legend BATT OK is displayed. If the battery is flat the legend LO BATT is displayed.

Press the FLOW AND BATTERY CHECK again to return the pump to hold mode.



**APPLICABLE TO MODEL 224-PCMTX8 ONLY****7) SET-UP Key (No. 4)**

With the pump in hold mode, press the SET-UP key to enter setup mode. The LCD screen will show the legend SET UP DELAYED START and the right hand digit will flash.

In the setup mode the delayed start time, sample time and run time can be entered.

**8) MODE Key (No. 5)**

With the pump in the setup mode press the MODE key to sequence through the DELAYED START, SAMPLE PERIOD and PUMP PERIOD settings, indicated by the corresponding legends on the LCD screen. The function of these three settings is explained in the section 'Operating the Timer' on pages 16 to 19.

The required values for these three settings can be entered using the DIGIT SELECT and DIGIT SET keys.

**9) DIGIT SELECT key (No. 6)**

With the pump in the setup mode and the required time setting selected, press the DIGIT SET key to cycle through the four timer digits on the display. The currently selected digit is indicated by flashing on and off. When the required digit is selected it can be set to the required value using the DIGIT SET key.

**10) DIGIT SET key (No. 7)**

With the pump in the setup mode, the required time setting selected and the required digit selected, press the DIGIT SET key to increment the value of the digit from 0 to 9 and back to 0.

The timer function features three settings used to achieve the various modes of operation:

1. DELAYED START - The time period in minutes that will elapse prior to the pump starting to run. Setting this value to zero disables the delayed start function.
2. SAMPLE PERIOD - The time period over which sampling will occur. Works in conjunction with the PUMP PERIOD. Setting this value to zero will disable the timed run function and the pump will run continuously until stopped using the START/HOLD key.
3. PUMP PERIOD - The time period in minutes during which the pump is actually running. If the PUMP PERIOD is set the same or to a higher value than the SAMPLE PERIOD, the pump will run continuously for the duration of the SAMPLE PERIOD. If the PUMP PERIOD is set to a lower value than the SAMPLE PERIOD then the pump will automatically calculate on and off periods to apportion the required PUMP PERIOD time over whole of the SAMPLE PERIOD time.

### **Setting a Simple Timed Run**

Example: 8 hour timed run with no delayed start.

1. Switch the pump on and press the START/HOLD key to enter hold mode.
2. Press the SET-UP key to enter setup mode.
3. Press the MODE key to cycle to the SAMPLE PERIOD setting option. The right hand digit will be flashing.
4. The timer is set in minute values. Calculate the required sample period in minutes - 8 hours = 480 minutes. Therefore the right hand digit should be set to 0.
5. Press the DIGIT SELECT key to select the second digit from the right.
6. Press the DIGIT SET key to increment the digit to 8.

7. Press the DIGIT SELECT key to select the third digit from the right.
8. Press the DIGIT SET key to increment the digit to 4. The digits should now read 0480.
9. Note that if a SAMPLE PERIOD time is entered, but the PUMP PERIOD is left at 0000, the pump will run continuously for the duration of the SAMPLE PERIOD.
10. The pump is now set up to run for 8 hours and switch off. To start the timed run press the START/HOLD key. The pump will start and the legend SAMPLE PERIOD will flash on and off in the top right of the LCD screen. At the end of the 8 hours (480 minutes) the pump will automatically stop and the display will show the legends HOLD and SAMPLE OVER, and the elapsed run time. Should the pump prematurely stop during the sample period the actual elapsed run time will be displayed.

### **Setting a Timed Run with Delayed Start**

Example: 8 hour timed run with a 2 hour delayed start

1. Switch the pump on and press the START/HOLD key to enter hold mode.
2. Press the SET-UP key to enter setup mode.
3. The right hand digit of the START DELAY time will be flashing, the required start delay time in minutes can now be entered. 2 hours = 120 minutes. Therefore leave the right hand digit set at 0.
4. Press the DIGIT SELECT key to select the second digit from the right.
5. Press the DIGIT SET key to increment the digit to 2.
6. Press the DIGIT SELECT key to select the third digit from the right.
7. Press the DIGIT SET key to increment the digit to 1.
8. The START DELAY time is now set to 120 minutes.

9. Press the MODE key to cycle to the SAMPLE PERIOD setting option. The right hand digit will be flashing.
10. The timer is set in minute values. Calculate the required sample period in minutes - 8 hours = 480 minutes. Therefore the right hand digit should set to 0.
11. Press the DIGIT SELECT key to select the second digit from the right.
12. Press the DIGIT SET key to increment the digit to 8.
13. Press the DIGIT SELECT key to select the third digit from the right.
14. Press the DIGIT SET key to increment the digit to 4. The digits should now read 0480.
15. Note that if a SAMPLE PERIOD time is entered, but the PUMP PERIOD is left at 0000, the pump will run continuously for the duration of the SAMPLE PERIOD.
16. The pump is now set to start after a delay of 2 hours, run for 8 hours and then switch off. To start the timed run press the START/HOLD key. The LCD screen will show the legend DELAYED START flashing in the bottom left of the screen and the start delay time will count down from 120 minutes. At the end of the start delay the pump will automatically start and the legend SAMPLE PERIOD will flash on and off in the top right of the LCD screen. At the end of the 8 hours (480 minutes) the pump will automatically stop and the display will show the legends HOLD and SAMPLE OVER, and the elapsed run time. Should the pump prematurely stop during the sample period the actual elapsed run time will be displayed.

### Setting an Intermittent Sample

Intermittent sampling allows a sample to be taken over a period of up to 9999 minutes (approximately one week) and can prove extremely useful for environmental or ambient monitoring. To sample over a period of one week and produce an average measurement, the pump is set to actually draw air for a period that the battery can handle such as 8 hours over the 7 day period.

Example: 8 hours running over a period of 24 hours

1. Switch on the pump and enter SET-UP mode. A DELAYED START time can be entered if required.
2. Press the MODE key to cycle to the SAMPLE PERIOD setting and enter 1440 minutes (24 hours) using the DIGIT SELECT and DIGIT SET keys.
3. Press the MODE key to cycle to the PUMP PERIOD setting and enter 480 minutes (8 hours) using the DIGIT SELECT and DIGIT SET keys.
4. The pump is now set for intermittent sampling, for a total of 8 hours over a period of 24 hours. To start the intermittent sample run press the START/HOLD key. The pump automatically calculates the required on/off timing strategy to apportion the PUMP PERIOD time over the SAMPLE PERIOD time. The pump will start and the legend SAMPLE RUNNING will be indicated in the top right of the LCD screen and the legend PUMP PERIOD will flash in the bottom right of the screen. The timer display will increment showing the total elapsed time. To view the actual elapsed pump running time press and hold the DIGIT SET / PUMP RUN TIME key. The display will return to the total elapsed time when the key is released.
5. At the end of the intermittent sample run the display will show the legends HOLD and SAMPLE OVER, and the total elapsed time. Press and hold the DIGIT SET / PUMP RUN TIME key to view the elapsed pump run time.

## Setting a Repeat Run

To repeat a timed run at another time DO NOT switch the pump off using the on/off switch. Leave the pump switched on with the LCD screen active. To re-run the program press the SET-UP key and then the START/HOLD key. The pump will now repeat the timed run from the start.

To quickly clear a timed run from the pump's memory switch the pump off and on using the ON/OFF switch.

**Note:** The battery pack can be safely charged when the pump is left switched on.

# Low Flow Sampling

The standard compensated flow range of the Universal MTX series pumps is 1000 to 4000 ml/min. To operate at flows in the range 5 to 500 ml/min an optional low flow adapter / tube holder is required. Low flow adapters are available for simultaneous sampling using one, two, three or four sample tubes (refer to the sampling accessories guide on pages 26 and 27 for details). The low flow adapters incorporate throttle valve(s) to set the low flow rate.

To work with the low flow adapter the pump incorporates a 'constant pressure controller' regulator to provide a constant suction at the outlet of the low flow adaptor, ensuring stable airflow through the sample tube(s) once the flow has been set using the throttle valve(s).

To enable or disable low flow mode a low flow mode control is located beneath the smaller of the two knurled metal cap screws on the top of the pump.

Unscrew and remove the cap screw, and use the large bladed screwdriver attachment of the supplied toolkit to unscrew the low flow mode control anti-clockwise by three turns to enable low flow mode.

To disable low flow mode screw the low flow mode control in fully clockwise.

## To Set Up For Low Flow Sampling -

First ensure that low flow mode is **disabled** as detailed above. Ensure that the low flow adapter is not connected to the pump inlet hosetail at



this point.

Stand the pump upright on a level surface and set the pump running. Set the pump flow rate to approximately 1.5 l/min. The built in flow indicator rotameter can be used to make this setting as only an approximate flow rate is required.

Turn off the pump and enable low flow mode as previously detailed.

No further adjustment of the pump flow rate is required.

The low flow adapter can now be connected to the pump inlet hosetail. Set the low flow rate with the throttle valve on the low flow adapter, using a suitable calibrated flowmeter (such as a chek-mate or rotameter).

**Note:** Always check that low flow mode has been disabled before carrying out high flow sampling subsequent to low flow sampling using the same pump.

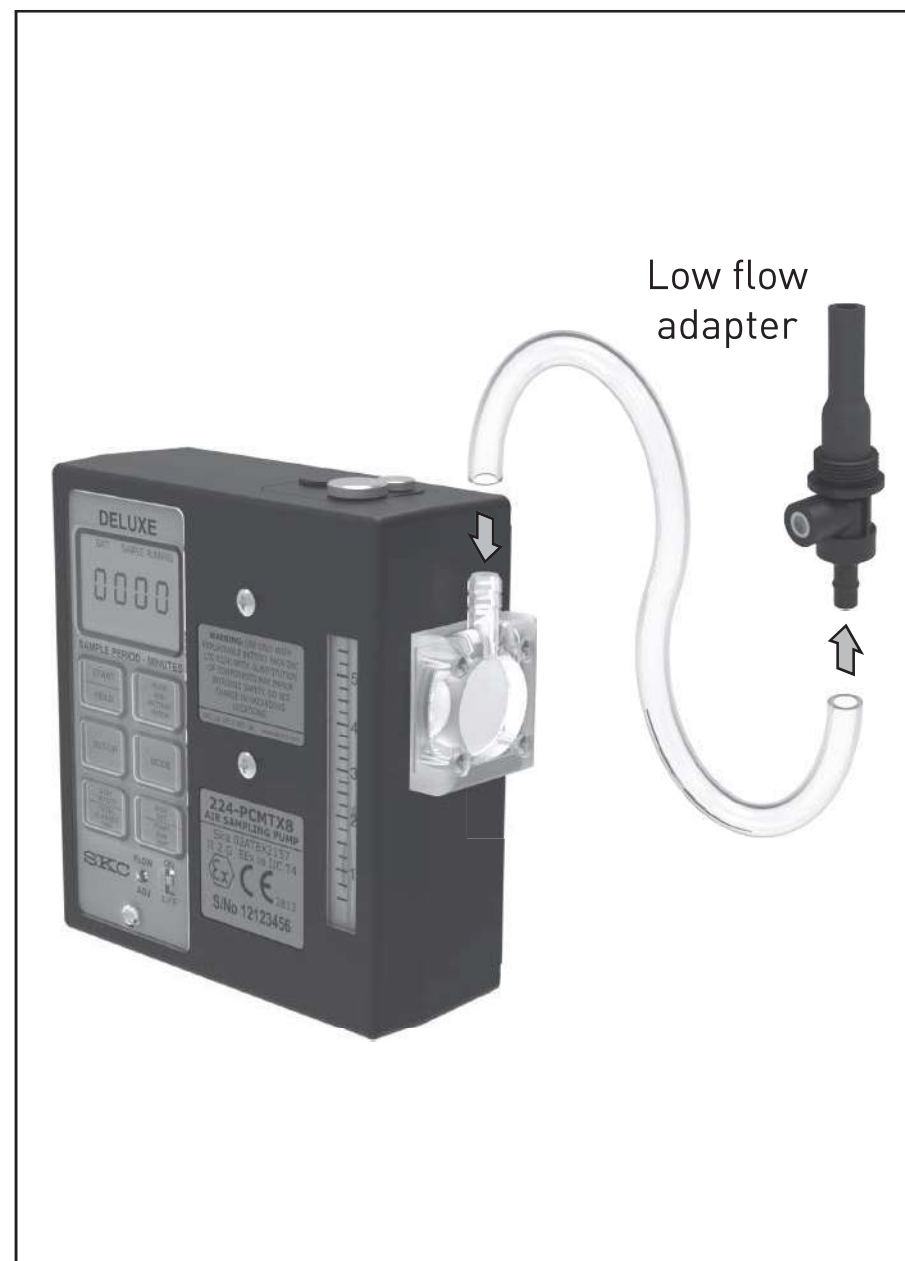

Possible Fault	Corrective Action
Battery pack will not charge	<ul style="list-style-type: none"> <li>• Check the battery charger by trying it with a different battery pack. Replace the battery charger if required.</li> <li>• Check the battery pack by connecting it to a known good battery charger. If the battery pack still will not charge replace the battery pack.</li> </ul>
Pump will not operate	<ul style="list-style-type: none"> <li>• Check for faulty battery pack by trying a known good battery pack. Replace the battery pack if required.</li> </ul>
Pump flow faults continuously (224-PCMTX4 & 224-PCMTX8 models only)	<ul style="list-style-type: none"> <li>• Filter media back pressure too high. Try a lower flow rate and/or a less restrictive filter media if the sampling method being used allows this.</li> <li>• More than one filter accidentally fitted into sampling head. Ensure that only one filter is fitted into the sampling head.</li> <li>• Filter backing paper fitted in addition to / in place of filter media. Ensure that only the filter is fitted into the sampling head.</li> <li>• Pump particulate filter is blocked (appears black). Replace the particulate filter.</li> <li>• Tubing blocked or crimped. Replace tubing.</li> </ul>
Pump cannot achieve required flow rate	<ul style="list-style-type: none"> <li>• Battery pack voltage low. Fully charge the battery pack.</li> <li>• Filter media back pressure too high. Try a lower flow rate and/or a less restrictive filter media if the sampling method being used allows this.</li> <li>• Pump is in the low flow mode. Disable low flow mode.</li> <li>• Pump valves leaking. Replace valve plate assemblies.</li> </ul>



Possible Fault	Corrective Action
<p>Pump stops due to low battery before the end of the required sample period</p>	<ul style="list-style-type: none"> <li>• Battery pack not fully charged before starting sample run. Ensure battery pack is fully charged before starting a sample run.</li> <li>• Battery pack has reduced capacity as it nears end of life. Replace the battery pack.</li> <li>• Filter media back pressure too high. Try a lower flow rate and/or a less restrictive filter media if the sampling method being used allows this.</li> </ul>

## Battery Charging

- Charge battery pack fully before first use to ensure optimum performance.
- Full battery capacity will be achieved after 2 to 3 full charge / full discharge cycles.
- Use only SKC approved charger designated for this battery pack. Use of a non-SKC approved charger may impair battery performance or even cause irreparable damage, and will invalidate the battery pack warranty.

## Battery Performance

- Charging temperature - For optimum performance charge NiMH batteries between 0 and +40°C.
- Do not overcharge - For optimum performance disconnect battery pack from charger after 24 hours.
- Discharge temperature - For optimum performance discharge NiMH batteries between -10 and +45°C (refer also to pump specifications on page 4 for other limitations on operating temperature for intrinsically safe applications).

## Battery Maintenance

- Battery cycling during regular use - Available battery capacity may be reduced when battery is only partially discharged during each use. To maintain optimum capacity during regular battery use, cycle battery once a month. To cycle battery, run pump until low battery shutdown occurs, then fully charge battery.
- Long term storage and highly infrequent use -
  1. Charge battery fully prior to long term storage.
  2. Store in a cool, dry place at temperature between 0 and 30°C.
  3. Recharge battery at least once a year (or more frequently if stored at temperature above 30°C).
  4. Cycle battery 2 to 3 times after long term storage to restore optimum capacity.

## Battery Testing

1. Connect SKC approved charger to battery pack. If charger indicator LED illuminates, battery pack charger input is ok. If charger LED does not illuminate, battery pack input fuse is blown - Replace battery pack.
2. Leave battery pack connected to charger to fully charge.
3. If pump does not function at all after full charge of battery pack, battery pack output fuse has blown, or battery cells have failed or are at end of life - Replace battery pack.
4. If pump functions after full charge of battery pack but gives significantly reduced run times before low battery shutdown, battery cells are failing or are at end of life - Replace battery pack.

## Battery Replacement

Refer to pump diagram on page 10. To remove the battery pack unscrew and remove the two battery screws (No. 25). Carefully slide the battery pack sideways out from under the metal belt clip (No.22) and remove the battery pack.

Fit the replacement battery by sliding it under the metal belt clip. Take care to ensure that the pins of the pump power connector engage into the holes in the socket connector on the battery pack. Secure the battery pack with the two screws. Do not apply excessive force when tightening the screws. Charge the new battery pack fully before use.

## Battery Disposal

- The EU Battery Directive and equivalent legislation in other countries requires that all batteries and battery packs are disposed of correctly at the end of their working life. This means that they must be collected and treated separately from other waste.
- Please ensure that any end-of-life SKC battery packs are collected and recycled or disposed of correctly.

# Universal MTX Pump Components

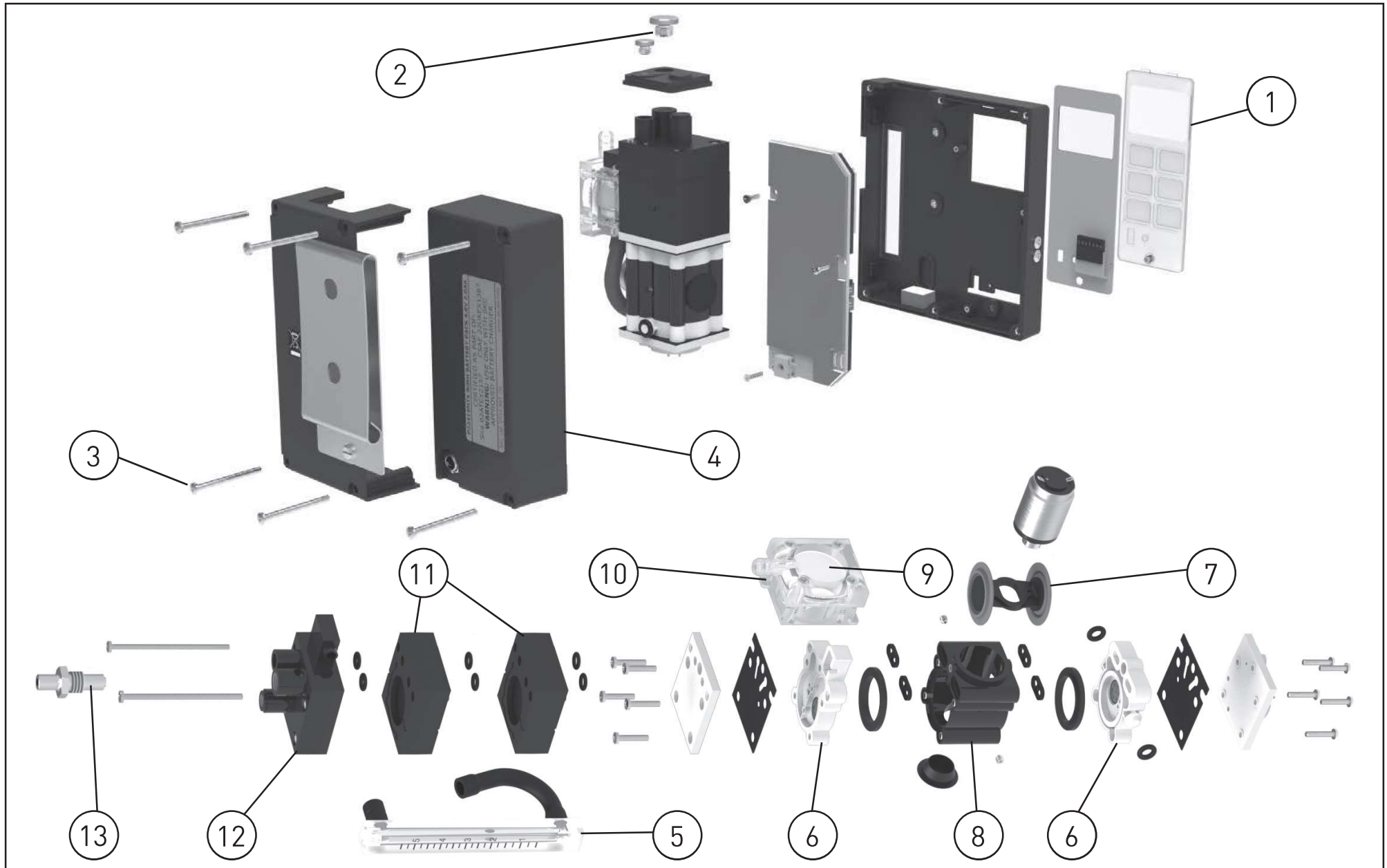

Item	Part No.	Description	Item	Part No.	Description
1	P22433C	Keypad cover plate	8	P22417G	Pump body
2	P22433RGY	Cap screws (set of 2)	9	P22409	Inlet filter & O ring kit (3 filters & 3 O rings)
3	P22433ES	External screw pack	9	P2240901	Inlet filter (pack of 10)
4	P22419MTX	Battery pack 4.8V 2.0Ah NiMH	10	P22417D	Filter housing assembly (includes 1 inlet filter & 1 O ring)
5	P22433L	Flow meter assembly	11	P22417K	Pulsation dampener (set of 2)
6	P22417F	Valve plate assembly (set of 2)	12	P22417J	Regulator assembly
7	P22417H	Yoke / diaphragm assembly	13	P22417C	Pressure (exhaust) port fitting

SKC recommend that our air sampling pumps are regularly serviced by one of our Authorised Service Centres. Due to the safety implications associated with the incorrect repair of ATEX certified intrinsically safe products for use in potentially explosive atmospheres, it is our policy to only supply the complete range of replacement parts to our Authorised Service Centres who are trained in the service and repair of these products.

Care must be taken when dis-assembling and re-assembling the pump to replace the above listed internal parts to ensure that no components are damaged or incorrectly assembled as this could affect pump performance and/or invalidate the ATEX certification of the pump. Do not apply excessive force when tightening the screws. If in any doubt contact your local distributor or SKC on +44 (0) 1258 480188.

The range of replacement parts listed above is available to all customers. If the required part is not listed, contact SKC on +44 (0) 1258 480188.

Note: Table item numbers correspond to the ringed numbers shown in the figures on page 26 of this manual.

Part No.	Description
<b>Key Accessories</b>	
223-203A	Single battery charger 100-240V ~ 50/60Hz supply with UK/EU/US/AUS mains plugs
223-103A	Five station battery charger 100-240V ~ 50/60Hz supply with UK/EU/US/AUS mains plugs
223-305B	Battery eliminator 230V ~ 50Hz supply with EU 2 pin mains plug
223-305C	Battery eliminator 230V ~ 50Hz supply with UK 3 pin mains plug
375-00205	chek-mate flowmeter 20 - 500 ml/min accuracy $\pm 1\%$ of reading ( $\pm 2.5\%$ at 20 to 50 ml/min)
375-0550	chek-mate flowmeter 0.5 - 5.0 l/min accuracy $\pm 1\%$ of reading ( $\pm 2.5\%$ at 0.5 to 0.75 l/min)
393-002025	Rotameter 20 - 250 ml/min accuracy $\pm 2.5\%$ of full scale
393-0334	Rotameter 0.3 - 3.4 litre/min accuracy $\pm 2.5\%$ VDI/VDE 3513-2:2008
<b>Dust Sampling Accessories</b>	
225-70A	I.O.M. sampler in plastic complete with two part plastic filter cassette and clip
225-76A	I.O.M. sampler in stainless steel complete with two part stainless steel filter cassette and clip
225-79A	I.O.M. sampler in plastic complete with two part stainless steel filter cassette and clip
225-71A	I.O.M. two part plastic filter cassette with cap and clip
225-75A	I.O.M. two part stainless steel filter cassette with cap and clip
391-01	'Calidaptor' flow calibration adapter for I.O.M. sampler
225-772	I.O.M. foam plug for respirable and multi-dust sampling (pack of 10)
225-69	Cyclone sampler in plastic with plastic cassette for 25mm diameter filters
225-69-37	Cyclone sampler in plastic with plastic cassette for 37mm diameter filters
225-62	Cyclone plastic cassette for 25mm diameter filters with clip

Part No.	Description
225-62-37	Cyclone plastic cassette for 37mm diameter filters with clip
225-67-10	Filter transport cassette for 25mm diameter filters (pack of 10)
<b>Gas / Vapour Sampling Accessories</b>	
224-26-01	Single adjustable low flow adapter / tube holder
224-26-02	Double adjustable low flow adapter / tube holder
224-26-03	Triple adjustable low flow adapter / tube holder
224-26-04	Quadruple adjustable low flow adapter / tube holder
224-29A	Protective cover type A 6mm diameter x 70mm
224-29B	Protective cover type B 8mm diameter x 110mm
224-29C	Protective cover type C 10mm diameter x 150mm
224-29D	Protective cover type D 10mm diameter x 220mm
224-29P	Protective cover for low volume PUF tubes
224-29V	Tube holder for OVS tube
810-722	Tube tip breaker

If the required item is not listed, contact your supplier or SKC sales on +44 (0) 1258 480188.

SKC provide an extensive range of sampling media, including filters, sorbent tubes and impingers. The full range can be found in the current SKC catalogue and at [www.skcltd.com](http://www.skcltd.com)

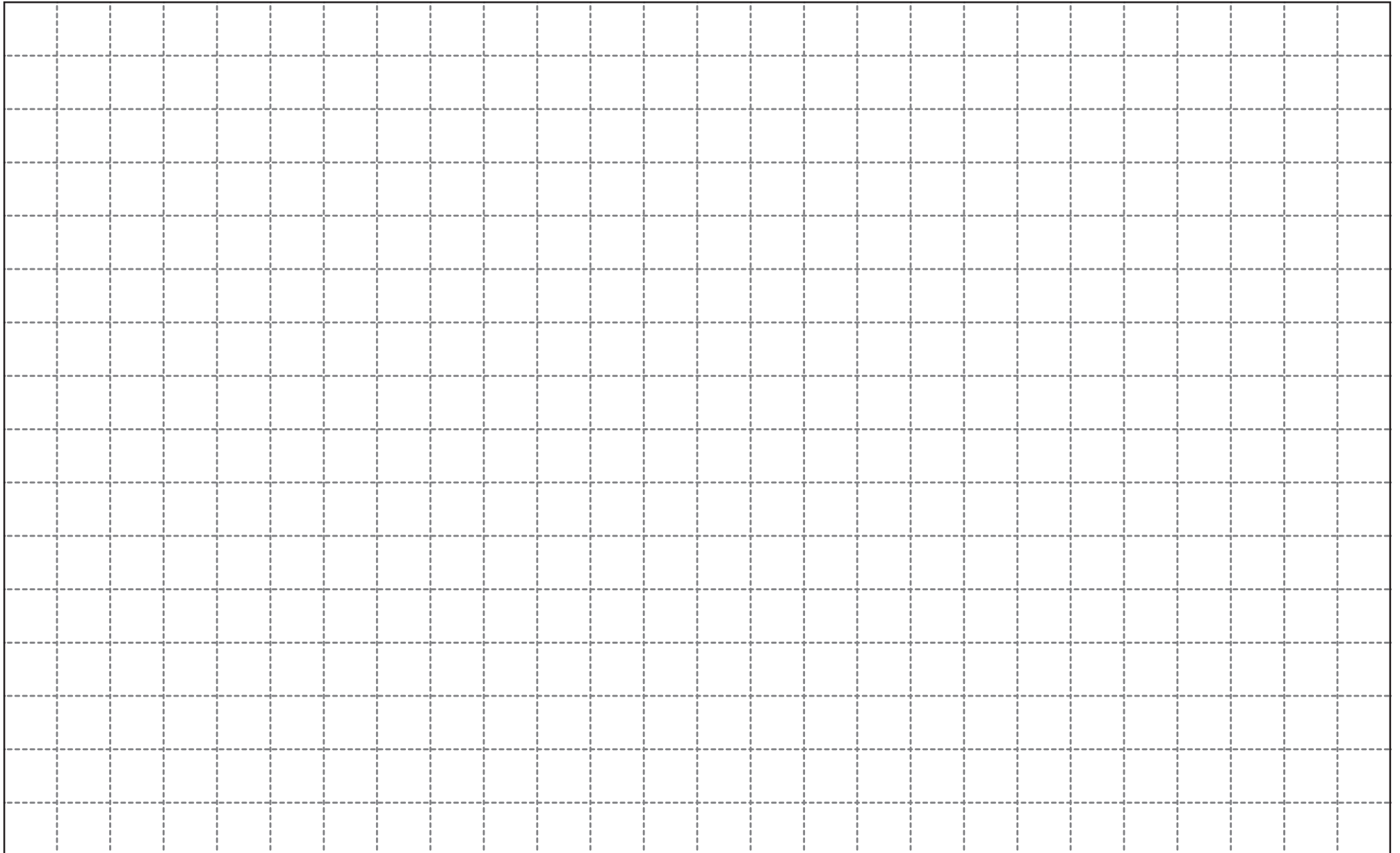



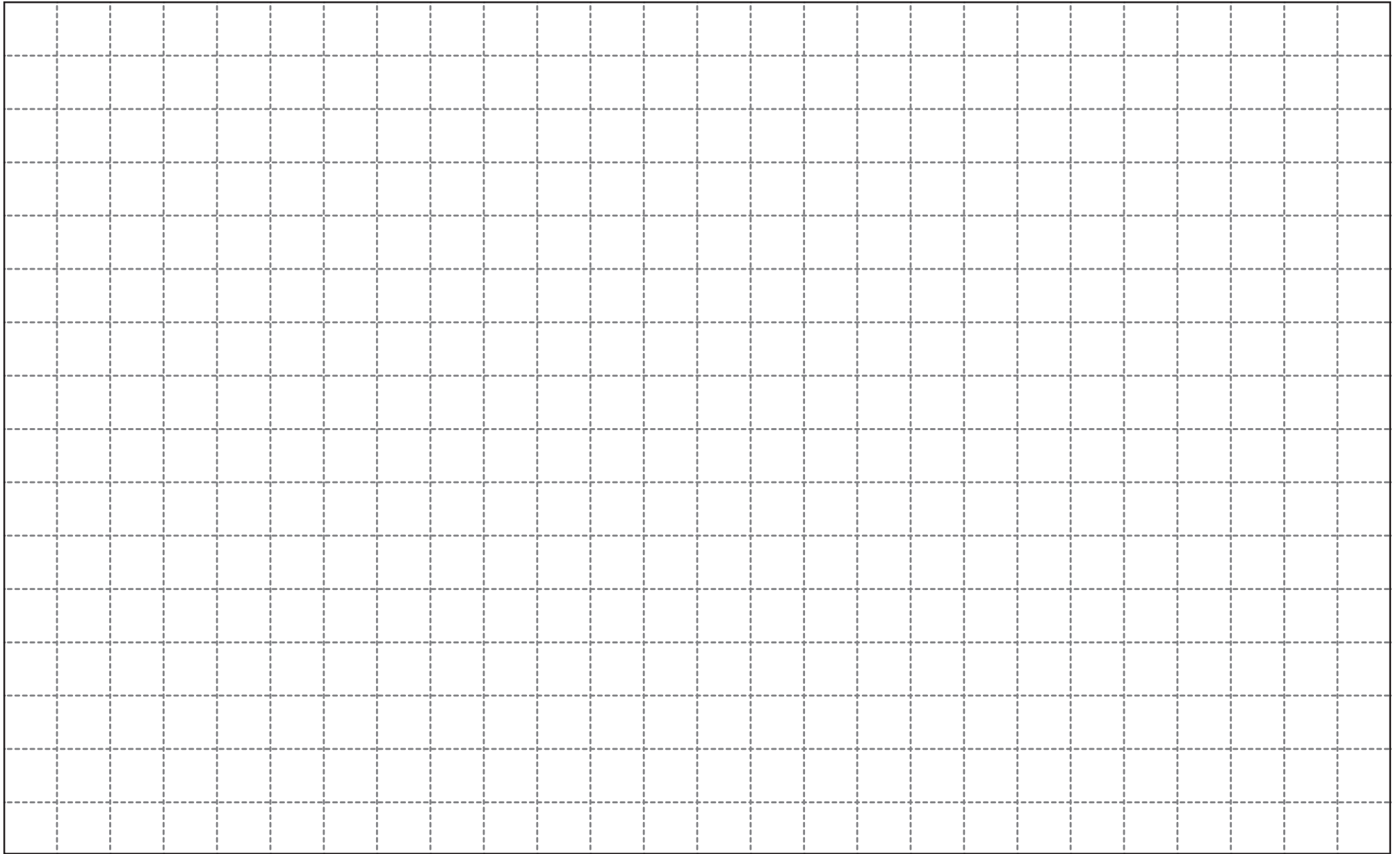

## Limited One Year Warranty

1. SKC warrants that this instrument, and each of its component parts, provided for occupational health and safety applications is free from defects in workmanship and materials under normal use for a period of one (1) year. This warranty DOES NOT cover any claims due to abuse, misuse, neglect, alteration, or accident, or use in application for which the instrument was either not designed or not approved by SKC, or, due to the buyer's failure to maintain normal maintenance, improper selection or misapplication. The warranty also DOES NOT cover any claims due to the use of a non-SKC approved charger to charge the battery pack. This warranty shall further be void if changes or adjustments to the instrument are made by a person other than an employee of the seller or, if the operating instructions furnished at the time of installation are not complied with.

2. SKC hereby expressly disclaims all warranties either expressed or implied, including any implied warranties of merchantability or fitness for a particular purpose and neither assumes nor authorises any person to assume for it any liability in connection with the sale of these instruments. No description of the goods being sold has been made a part of the basis of the bargain or has created or amounted to an express warranty that the goods will conform to any such description. Buyer shall not be entitled to recover from SKC any consequential damages; damages to property, damages for loss of use, loss of time, loss of profits or income or any other incidental damages. Nor shall the Buyer be entitled to recover from SKC any consequential damages resulting from defect of the instrument.

3. This warranty extends only to the original purchaser of the warranted instrument during the term of the warranty, the buyer may be required to present proof of purchase in the form of a paid receipt for the instrument.

4. In the event of a defect, malfunction, or other failure of the instrument not caused by any misuse or

damage to the instrument while in the possession of the Buyer, SKC will remedy the failure or defect without charge to the buyer. The remedy will consist of service or replacement of the instrument, or refund of the purchase price, at the option of SKC. However, SKC will not elect refund unless it is unable to provide replacement and repair is not commercially practicable.

5. The terms of this warranty begin on the date the instrument is delivered to the Buyer and continue for a period of one (1) year.

6(a) To obtain performance of any obligation under this warranty, the buyer shall return the instrument, freight prepaid to SKC at the following address:-

SKC Limited  
11 Sunrise Park  
Higher Shaftesbury Road  
Blandford Forum  
Dorset DT11 8ST  
Phone: +44 (0) 1258 480188

6(b) To obtain further information on the warranty performance contact SKC.

7. This warranty is provided under English law.

8. No other warranty is given by SKC in conjunction with this sale.

The disclaimers and limitations shall not affect the statutory rights of a consumer.

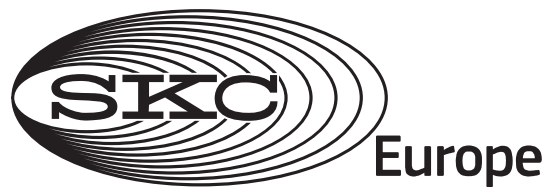

## Air Sampling Solutions & Expertise

---

**SKC Limited** 11 Sunrise Park, Higher Shaftesbury Road, Blandford Forum, Dorset DT11 8ST **United Kingdom**

**Phone:** +44 (0) 1258 480188 **Email:** [info@skcltd.com](mailto:info@skcltd.com) **Web:** [www.skcltd.com](http://www.skcltd.com)