

Hot Wire Thermo-Anemometer

Model 407123

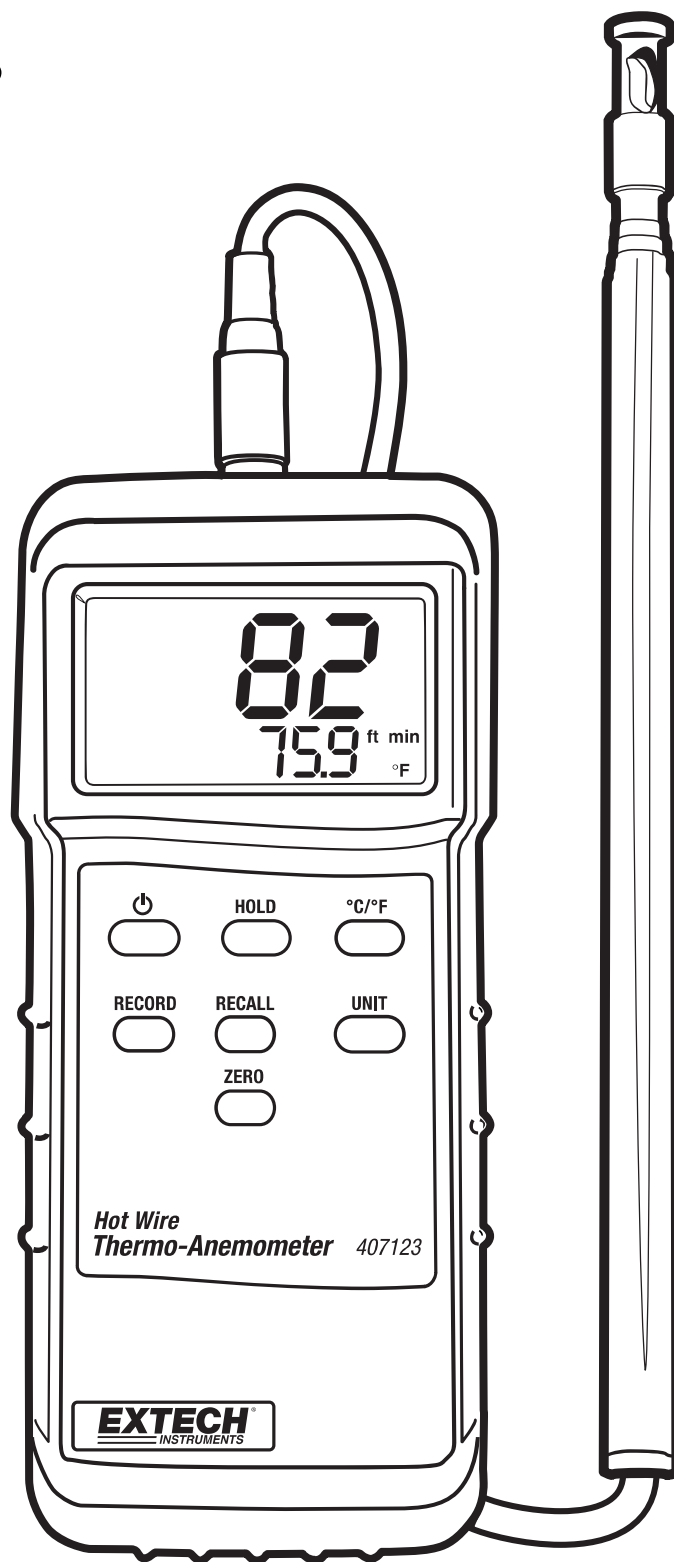

Introduction

Congratulations on your purchase of the Extech Hot Wire Anemometer. This instrument measures air flow and temperature by placing the sensor into an airway such as a duct or a vent. The sensor is situated at the end of the telescoping wand for convenience and has a protective sliding cover. The meter includes an RS-232 PC Interface jack for use with the Model 407001 Data Acquisition software and interface cable kit. This meter is shipped fully tested and calibrated and, with proper use, will provide years of reliable service.

Description

Meter Description

1. LCD display – Indicates air velocity and temperature readings, units of measure, low battery icon, and other user alerts
2. Push-buttons:
 - POWER: Turn meter ON and OFF
 - HOLD: Freezes the displayed reading
 - C/F: Select the temperature units
 - RECORD: Press to track the highest (MAX) and lowest (MIN) reading
 - RECALL: Displays MAX/MIN readings
 - UNIT: Air velocity units of measure
 - ZERO: Press to zero the display (sensor cover must be closed)
3. Protective holster – Rubber jacket that surrounds the meter (must be removed to access battery compartment)
4. Battery compartment - Located on the lower back of the meter
5. PC Interface jack – Accepts a 3.5mm plug from a PC interface cable (cable and data acquisition software available using part number 407001)
6. Sensor input jack – Insert the sensor plug
7. Sensor opening – Air must flow through this opening for proper measurement
8. Telescoping sensor handle – Extends to 39" (1m)
9. Sensor protective cover – Slide DOWN to open when in use and slide UP to protect sensor when not in use (close the cover when zeroing the meter)

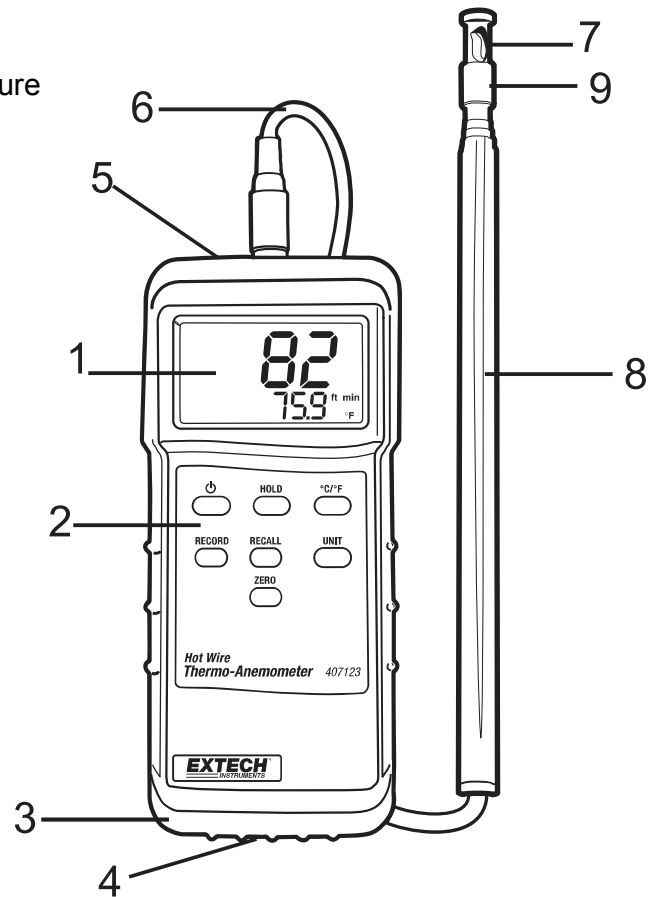

Sensor Tip Description

1. Air Direction indentation
2. Air Velocity Sensor
3. Sensor cover in lower (measurement) open position
4. Sensor cover in upper (zero) closed position
5. Temperature sensor

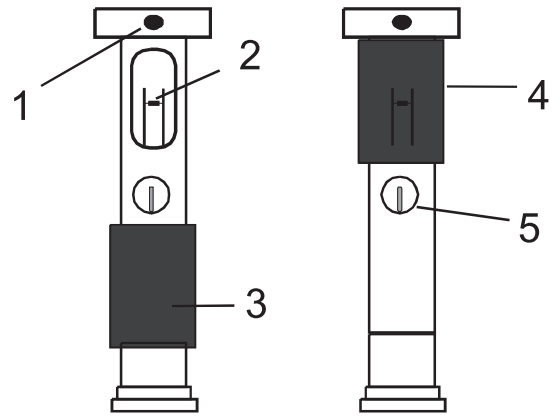

Operation

Initialization and Zero

The meter should always be zeroed at temperature before use using the ZERO button. Do not rely on the initial zero display.

Notes:

- The meter does not display negative numbers.
- Open antenna to desired length.
 1. Connect the sensor to the input jack on top of the meter and open antenna to desired length.
 2. Turn on the meter using the Power button. The meter will perform a self-test during which the display will count down from 9 to 0.
 3. Select the desired temperature units using the C/F select button. The LCD will reflect the selection.
 4. Select the desired air velocity units using the UNIT button. The LCD will reflect the selection.
 5. Place the sensor cover in the UP (ZERO) position.
 6. Place the sensor in the area to be measured and allow a short time for the sensor to reach the temperature of the air under test.
 7. Press the ZERO button to zero the meter.

Taking Measurements

1. Zero the meter as described above.
2. Slide the air velocity sensor cover down.
3. Place the sensor in the air current to be measured. Have the air flow meet the sensor head in the direction of the indentation on the sensor head.
4. View the air velocity and temperature readings on the LCD Display. The large main LCD display indicates the Air Velocity reading. The lower LCD sub-display indicates the temperature reading.



MIN and MAX Function

1. To begin capturing the Minimum (MIN) and Maximum (MAX) readings, press the RECORD button. The 'REC' icon will appear on the LCD.
2. Take readings as described previously.
3. Press the RECALL button to view the Maximum reading encountered since the RECORD button was pressed. The 'MAX' display icon will appear along with the maximum reading.
4. Press RECALL again to view the minimum reading (MIN).
5. Press the RECORD button to exit this mode and return to normal operation.

Data Hold

To freeze the LCD display, press the HOLD button. The 'DH' display icon will appear on the LCD. Press the HOLD button again to return to normal operation (the 'DH' hold icon will switch off).

Battery Replacement

When the low battery indicator (LBT) appears on the LCD or if the LCD does not switch on when the POWER button is pressed, replace the batteries.

1. Remove the protective rubber holster that encapsulates the meter.
2. Open the rear battery compartment by prying the compartment off with a flat-head screwdriver or a coin.
3. Replace the six 'AAA' 1.5V batteries observing polarity.
4. Replace the battery compartment cover and the protective holster.

PC Interface

The meter is equipped with an RS-232 PC Interface jack at the top of the meter (next to the sensor input jack). For streaming of data to a PC via the RS232 Output jack, the optional 407001-USB kit (RS232 to USB cable and driver CD) along with the 407001 software (available free at www.extech.com) are required.

Specifications

General Specifications

Circuit configuration	Custom one-chip LSI microprocessor circuit
Display	3-1/2 digit (2000 count) dual LCD display
Measurements	m/s (meters per second), km/h (kilometers per hour), ft/min (feet/minute), knots (nautical miles per hour), MPH (miles per hour), Temperature: °C, °F
Data hold	Freezes reading on display
Sensor Structure	Air velocity sensor: Glass bead thermistor Temperature sensor: Precision thermistor
Min/Max Recording	Record and Recall Maximum (MAX) and Minimum (MIN) readings
PC Interface	RS 232 PC serial interface jack for use with Model 407001 software and interface cable kit
Operating Temperature	32 to 122°F (0 to 50 °C)
Operating Humidity	Max. 80% RH
Power Supply	Six (6) 1.5V 'AAA' batteries
Power Consumption	Approx. 30 mADC
Weight	0.78 lb (355 g) including batteries & probe
Dimensions	Main instrument: 7.1 x 2.8 x 1.3" (180 x 72 x 32 mm) Sensor: 0.5" (12mm) diameter Telescope: 7' (2.1m) maximum length with cable

Range Specifications

Units	Range	Resolution	Accuracy
m/s	0.2 to 20.0 m/s	0.1 m/s	$\pm(3.0\%rdg+0.3m/s)^*$
km/h	0.7 to 72.0 km/h	0.1 km/h	$\pm(3.0\%rdg+1.1km/h)^*$
ft/min	40 to 3940 ft/min	1 ft/min	$\pm(3.0\%rdg+59ft/min)^*$
MPH	0.5 to 45.0 MPH	0.1 MPH	$\pm(3.0\%rdg+0.67MPH)^*$
knots	0.4 to 38.8 knots	0.1 knots	$\pm(3.0\%rdg+0.58knots)^*$
*or, $\pm(1.0\%FS+3d)$ whichever is greater			
Temperature	32 to 122 °F (0 to 50°C)	0.1 °F and °C	3.6 °F (2 °C)

Note: m/s: meters per second; km/h: kilometers per hour; ft/min: feet per minute; Knots: nautical miles per hour; MPH: miles per hour

Useful Equations and Conversions

Area equations

The volume of air flowing through a duct or vent can be determined by taking the area of the duct in square units (i.e. square feet) and multiplying this value by the measured linear velocity (i.e., feet per minute). This gives: $\text{ft}/\text{min} \times \text{ft}^2 = \text{ft}^3/\text{min}$ (CFM)

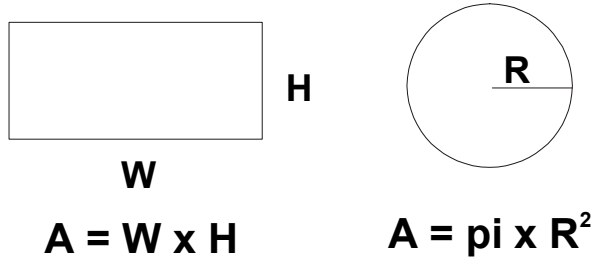

Cubic equations

CFM (ft³/min) = Air Velocity (ft/min) x Area (ft²)
CMM (m³/min) = Air Velocity (m/sec) x Area (m²) x 60

Units Conversion Table

	m/s	ft/min	knots	km/hr	MPH
1 m/s	1	196.87	1.944	3.6	2.24
1 ft/min	0.00508	1	0.00987	0.01829	0.01138
1 knot	0.5144	101.27	1	1.8519	1.1523
1 km/hr	0.2778	54.69	0.54	1	0.6222
1 MPH	0.4464	87.89	0.8679	1.6071	1

Warranty

*FLIR Systems, Inc. warrants this Extech Instruments brand device to be free of defects in parts and workmanship for **one year** from date of shipment (a six month limited warranty applies to sensors and cables). If it should become necessary to return the instrument for service during or beyond the warranty period, contact the Customer Service Department for authorization. Visit the website www.extech.com for contact information. A Return Authorization (RA) number must be issued before any product is returned. The sender is responsible for shipping charges, freight, insurance and proper packaging to prevent damage in transit. This warranty does not apply to defects resulting from action of the user such as misuse, improper wiring, operation outside of specification, improper maintenance or repair, or unauthorized modification. FLIR Systems, Inc. specifically disclaims any implied warranties or merchantability or fitness for a specific purpose and will not be liable for any direct, indirect, incidental or consequential damages. FLIR's total liability is limited to repair or replacement of the product. The warranty set forth above is inclusive and no other warranty, whether written or oral, is expressed or implied.*

Calibration, Repair, and Customer Care Services

FLIR Systems, Inc. offers repair and calibration services for the Extech Instruments products we sell. NIST certification for most products is also provided. Call the Customer Service Department for information on calibration services available for this product. Annual calibrations should be performed to verify meter performance and accuracy. Technical support and general customer service is also provided, refer to the contact information provided below.

Support Lines: U.S. (877) 439-8324; International: +1 (603) 324-7800

Technical Support: Option 3; E-mail: support@extech.com

Repair & Returns: Option 4; E-mail: repair@extech.com

Product specifications are subject to change without notice

Please visit our website for the most up-to-date information

www.extech.com

FLIR Commercial Systems, Inc., 9 Townsend West, Nashua, NH 03063 USA

Copyright © 2014-2016 FLIR Systems, Inc.

All rights reserved including the right of reproduction in whole or in part in any form

www.extech.com

Garantie

FLIR Systems, Inc. garantit que cet appareil Extech Instruments est exempt de défauts matériaux et de fabrication pendant un an à partir de la date d'envoi (une garantie limitée de six mois s'applique aux capteurs et aux câbles). Si le renvoi de l'appareil pour réparation devient nécessaire durant ou après la période de garantie, contactez le service client pour autorisation. Pour obtenir les coordonnées, visitez le site Web suivant : www.extech.com. Un numéro d'autorisation de retour (AR) doit être délivré avant tout retour de produit. L'expéditeur prend à sa charge les frais d'expédition, le fret, l'assurance et l'emballage correct de l'appareil afin de prévenir toute détérioration durant le transport. Cette garantie ne s'applique pas aux dommages imputables à l'utilisateur, tels que l'usage impropre ou abusif, un mauvais câblage, une utilisation non conforme aux spécifications, un entretien ou une réparation incorrecte, ou toute modification non autorisée. FLIR Systems, Inc. déclinera spécifiquement toute garantie ou qualité marchande ou aptitude à l'emploi prévu, et ne sera en aucun cas tenu responsable pour tout dommage conséquent, direct, indirect ou accidentel. La responsabilité totale de FLIR est limitée à la réparation ou au remplacement du produit. La garantie définie ci-dessus est inclusive et aucune autre garantie, écrite ou orale, n'est exprimée ou implicite.

Calibrage, réparation et services après-vente

FLIR Systems, Inc. offre des services de calibrage et de réparation pour les produits Extech Instruments que nous commercialisons. Nous fournissons également une certification NIST pour la plupart des produits. Contactez notre service client pour toute information sur les services de calibrage disponibles pour ce produit. Un calibrage doit être effectué chaque année pour vérifier les performances et la précision du mètre. Nous offrons également une assistance technique et un service à la clientèle. Veuillez vous reporter aux coordonnées fournies ci-dessous.

Lignes d'assistance: États-Unis (877) 439-8324; international: +1 (603) 324-7800

Service d'assistance technique : Option 3 ; E-mail : support@extech.com

Réparations et retours : Option 4 ; E-mail : repair@extech.com

Les spécifications produit sont sujettes à modifications sans préavis.

Pour les toutes dernières informations, veuillez visiter notre site Web.

www.extech.com

FLIR Commercial Systems, Inc., 9 Townsend West, Nashua, NH 03063 USA

Copyright © 2014-2016 FLIR Systems, Inc.

Tous droits réservés, y compris la reproduction partielle ou totale sous quelque forme que ce soit.

www.extech.com

Garantía

FLIR Systems, Inc., garantiza este dispositivo marca Extech Instruments para estar libre de defectos en partes o mano de obra durante un año a partir de la fecha de embarque (se aplica una garantía limitada de seis meses para cables y sensores). Si fuera necesario regresar el instrumento para servicio durante o después del periodo de garantía, llame al Departamento de Servicio a Clientes para obtener autorización. Visite www.extech.com para Información de contacto. Se debe expedir un número de Autorización de Devolución (AD) antes de regresar cualquier producto. El remitente es responsable de los gastos de embarque, flete, seguro y empaque apropiado para prevenir daños en tránsito. Esta garantía no se aplica a defectos resultantes de las acciones del usuario como el mal uso, alambrado equivocado, operación fuera de las especificaciones, mantenimiento o reparación inadecuada o modificación no autorizada. FLIR Systems, Inc., rechaza específicamente cualesquier garantías implícitas o factibilidad de comercialización o idoneidad para cualquier propósito determinado y no será responsable por cualesquier daños directos, indirectos, incidentales o consecuentes. La responsabilidad total de FLIR está limitada a la reparación o reemplazo del producto. La garantía precedente es inclusiva y no hay otra garantía ya sea escrita u oral, expresa o implícita.

Servicios de calibración, reparación y atención a clientes

FLIR Systems, Inc., ofrece servicios de reparación y calibración para los productos que vendemos de Extech Instruments. Además ofrecemos certificación NIST para la mayoría de los productos. Llame al Departamento de Servicio al Cliente para solicitar información de calibración para este producto. Para verificar el funcionamiento y precisión se debe realizar la calibración anual. Además se provee Soporte Técnico y servicios generales al cliente, consulte la información de contacto en seguida.

Líneas de soporte: EE.UU. (877) 439-8324; Internacional: +1 (603) 324-7800

Soporte Técnico Opción 3; correo electrónico: support@extech.com

Reparación / Devoluciones: Opción 4; correo electrónico: repair@extech.com

Las especificaciones del producto están sujetas a cambios sin aviso

Por favor visite nuestra página en Internet para la información más actualizada

www.extech.com

FLIR Commercial Systems, Inc., 9 Townsend West, Nashua, NH 03063 USA

Certificado ISO 9001

Copyright © 2014-2016 FLIR Systems, Inc.

Reservados todos los derechos, incluyendo el derecho de reproducción total o parcial en cualquier medio

www.extech.com